

SERPAC 052

Electronics Enclosures

NOTES:
1. WHEN MACHINE OR I PLATES MODIFICATIONS ARE REQUIRED, USE THE CENTER OF THE BOX TO DIMENSION.

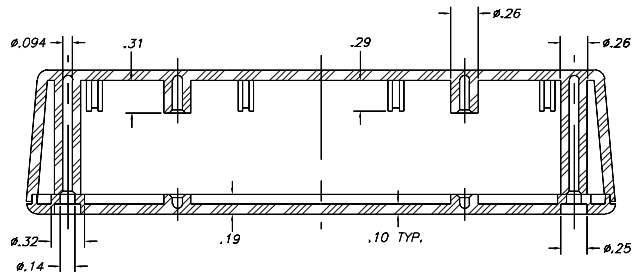
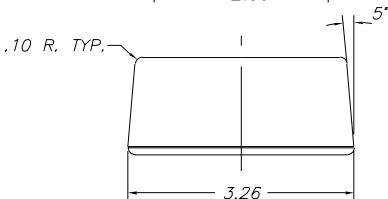
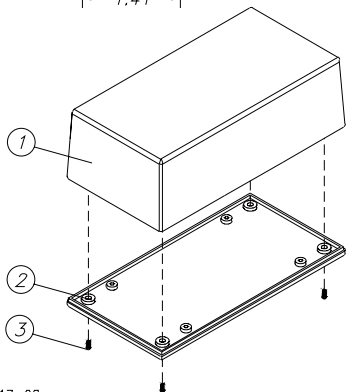
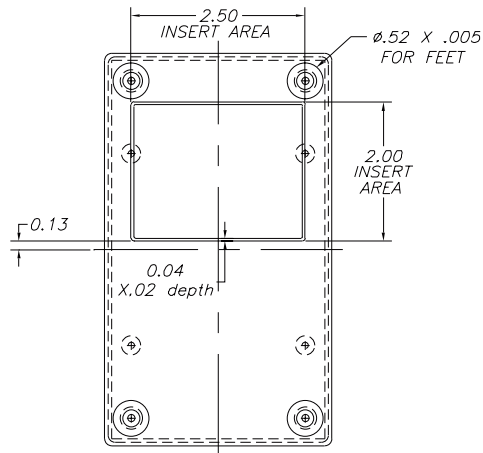
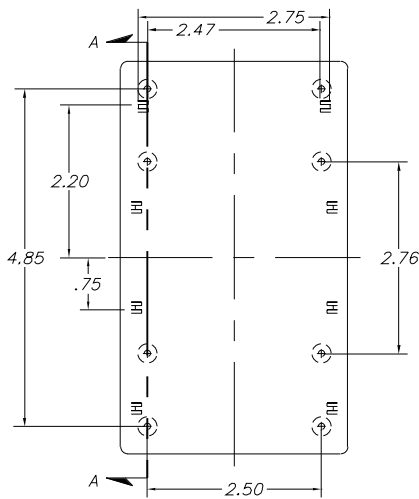
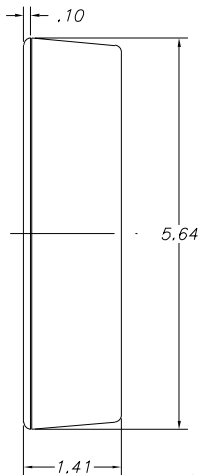

SECTION A-A

8-17-98.

ALL DIMENSIONS $\pm .010$

ITEM	PART NO.	DESCRIPTION	ACCESSORIES	
1	52	PLASTIC TOP	PART NO.	DESCRIPTION
2	05	PLASTIC BOTTOM	51	FEET
3	6005	SCREWS (4)	350	PROTOTYPE GRID BOARD (HORIZ.)
			450	PROTOTYPE CLAD BOARD (HORIZ.)